



SmartStar[®] CubePro[™]

Instruction Manual

Table of Content

Table of Content.....	2
1. Introduction	4
1.1. CubePro Features	4
1.2. CubePro™ Assembly Terms	5
2. CubePro Assembly.....	6
3. GOTONOVA™ 8401 Hand Controller	8
3.1. Key Description.....	8
3.2. The LCD Screen	9
3.3. Connection to a Computer	9
4. Getting Started	9
4.1. Level and Align the Mount	9
4.2. Setting Up the Mount	10
4.2.1. Set Up Time Zone	10
4.2.2. Set Up Daylight Saving Time	11
4.2.3. Set Mount Type	11
4.2.4. Set Anti-backlash	12
4.2.5. Go to the Moon	12
4.2.6. Initial Star Alignment	12
4.3. Turn Off the Mount.....	13
5. Use the CubePro.....	13
5.1. Manual Operation of a Telescope.....	13
5.2. Slew to an Object.....	13
5.2.1. Planets, Sun, Moon.....	13
5.2.2. Deep sky objects.....	13
5.2.3. Comets.....	13
5.2.4. Asteroids	14
5.2.5. Stars.....	14
5.2.6. Constellations.....	14
5.2.7. User Objects	14
5.2.8. Enter R.A. DEC	14
5.3. Sync to Target	14
5.4. Electric Focuser	14
5.5. Set Up Controller	14
5.5.1. Set Up Local Time.....	14
5.5.2. Set Up Site	14
5.5.3. Set N/S Hemisphere	14
5.5.4. Set Display Contrast	14
5.5.5. Set Eyepiece Light	15
5.5.6. Set Backlight	15
5.5.7. Set Anti-backlash	15
5.5.8. Set Key Beep	15
5.5.9. Set Mount Type.....	15
5.5.10. Reset All.....	15
5.5.11. Update Firmware.....	15
5.5.12. Set gear ratio.....	15

5.5.13. Set Language.....	15
5.6. Align.....	15
5.6.1. One Star Align.....	15
5.6.2. Two Star Align.....	15
5.6.3. Three-Star Align.....	16
5.6.4. Dis R.A axis error.....	16
5.6.5. Test Anti-backlash.....	16
5.6.6. Polaris Position.....	16
5.7. PEC Option.....	16
5.8. Set Up Tracking.....	16
5.9. User Objects.....	16
5.10. Auto Guide.....	16
5.11. Park Scope.....	16
5.12. To Park Position.....	16
6. Maintenance and Servicing.....	17
6.1. Maintenance.....	17
6.2. Troubleshooting.....	17
6.3. iOptron Customer Service.....	18
Appendix A. Technical Specifications.....	19
Appendix B. GOTO NOVA™ 8401 HC MENU STRUCTURE.....	20
Appendix C. GOTO NOVA™ Star List.....	22
Appendix D. Set Up USB-PC Connection.....	27
Appendix E. Firmware Upgrade.....	34
Appendix F. Use a PC to Control an iOptron Mount.....	37
Appendix G. RS-232 Command Set.....	38



WARNING!

NEVER USE A TELESCOPE TO LOOK AT THE SUN!
Looking at or near the Sun will cause instant and irreversible damage to your eye.
Children should always have adult supervision while observing.

1. Introduction

1.1. CubePro Features

CubePro™ GOTO altazimuth (A/A) Mount is the ideal portable mount to go with your traveling OTAs, such as a 60mm or 80mm ED refractor, a 90mm or 100mm Maksutov-Cassegrain or a 114mm Newtonian reflector. It can also be used to mount solar scopes.

It features a SmartStar® computerized control system with 130,000 objects and 8-line backlit LCD screen. A 32 channel internal GPS, easy alignment procedure and accurate GoTo and auto-tracking minimize the setup time.

1" stainless steel tripod with metal platform and metal hinges makes the mount very sturdy. Compact design of the tripod and the mount makes it easy to carry around in a travel case. The mount assembling takes less than 5 minutes.

Standard dovetail makes this mount compatible with many different OTAs.

CubePro™ is compatible with all ASCOM compliant planetarium programs and many other programs such as Sky X, Starry Night and Voyager.

Package Contents

The CubePro™ mount comes with the tripod in the same shipping box, which includes:¹

- Telescope Mount (with built - in GPS)
- AC Adaptor with cord
- 8401 Hand Controller
- Controller Cable
- USB cable
- Tripod
- Tripod bolt (with black shaft) and Tray Lock
- Tripod Tray
- 1.5 kg Counterweight and shaft

¹ US market only. Actual contents may vary from time to time.

1.2. CubePro™ Assembly Terms

1. Telescope (not included)
2. Dovetail Lock
3. Hand Controller
4. Altitude Lock
5. Mount
6. Tripod
7. Inner support/Tripod bolt
8. Tray
9. Tray lock
10. Counterweight (not shown)

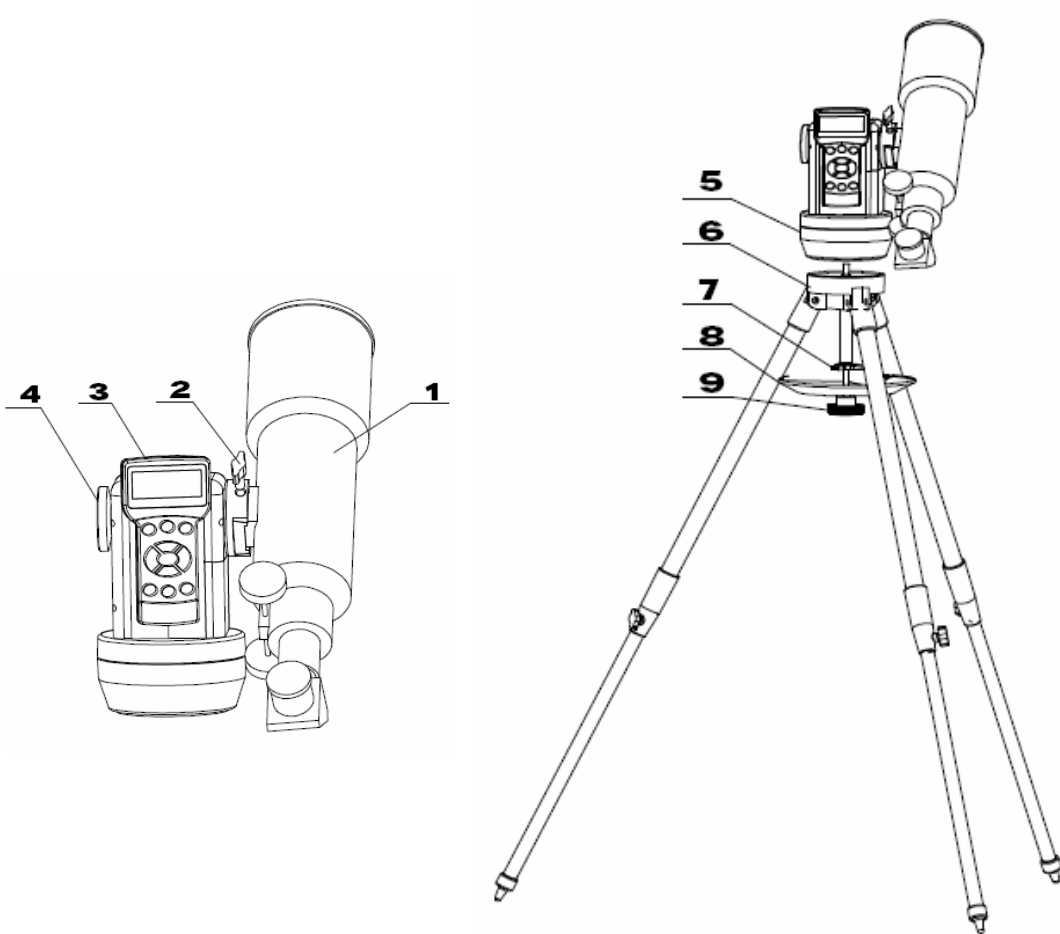











Figure 1. CubePro mount and tripod

2. CubePro Assembly

	<p>Step 1. Extend tripod legs to full extension.</p>
	<p>Step 2. Attach mount to tripod using the long bolt (#7). Slide tray on bottom of shaft. Then screw on round black knob (#9).</p>
	<p>Step 3. Installing Batteries Pull the batteries compartment cover (shown) open. Gently pull the batteries holder out of the compartment to avoid breaking the attached wires.</p>
	<p>Step 3a. Insert 8 AA batteries (not included) according to the diagrams on the holder.* Replace the holder back into the batteries compartment and replace the cover.</p> <p><i>Note: fit the batteries holder back into the compartment with the attached wires at the bottom right corner (see arrow in the photo).</i></p> <p>* Use only fresh batteries; do not mix fresh and old batteries; insufficient battery power may cause error messages.</p>
	<p>Step 4. Attaching Telescope Attach telescope to mount using the dovetail lock knob (#2).</p>

	<p>Step 6. Connecting Hand Controller</p> <p>Plug hand controller into any one of the HBX (handbox) ports on the mount. Plug in power plug if a AC adaptor is used. Turn on power. Now you are ready to observe. Use the 4 Arrow keys (▲▼◀▶) to rotate the scope Up, Down, Left, and Right. Use the Number key to change the slew speed from the slowest (1 - 1X) to the fastest (9 - MAX).</p> <p>The other HBX is reserved for accessories, such as electronic focuser, laser pointer and autoguider adapter. DO NOT plug non-iOptron accessories into the unit to avoid damaging the mount or accessories</p>
	<p>7. This step allows you to attach the counterweight to the mount. <i>(note: if you have a scope less than 7 lbs., attaching a counterweight is optional).</i></p> <p>Unlock and remove the altitude lock (#4). Screw on the counterweight shaft and tighten it.</p>
	<p>8. Slide the counterweight onto the counterbalance shaft. Next, insert the brass pin into the hole on the counterweight.</p>
	<p>9. Secure the counterweight by tightening the lock knob.</p> <p> Counter weight is heavy. Please handle with care to avoid injury!</p>

3. GOTONOVA™ 8401 Hand Controller



Figure 2. GOTONOVA 8401 Hand Controller

GOTONOVA™ 8401 hand controller (HC) is the standard controller for a CubePro, as shown in Figure 2.

3.1. Key Description

- MENU: Press “MENU” to enter the Main Menu.
- BACK: Move back to the previous screen, or end/cancel current operation, such as slewing.
- ENTER: Confirm an input, go to the next menu, select a choice, or slew the telescope to a selected object.
- Arrow (▲▼▶◀): Press ▲▼ buttons to move a telescope along the DEC direction, ▶◀ to move a telescope along the RA direction. Brows the menu or move the cursor in operating menu.
- Number Keys: Input numerical values. Also used to adjust speeds (1: 1X; 2: 2X; 3: 8X; 4: 16X; 5: 64X; 6: 128X; 7: 256X; 8: 512X; 9: MAX)
- Light Key(☀): Turns on/off the red LED reading light on the back of the controller.
- ? Key: For help or extra information.
- STOP/0 Key: Stop/Start tracking.
- HBX (Handbox) port: connect the HC to CubePro mount using a 6-wire RJ11 cable.
- USB port: connect the HC to a Computer via a USB cable.

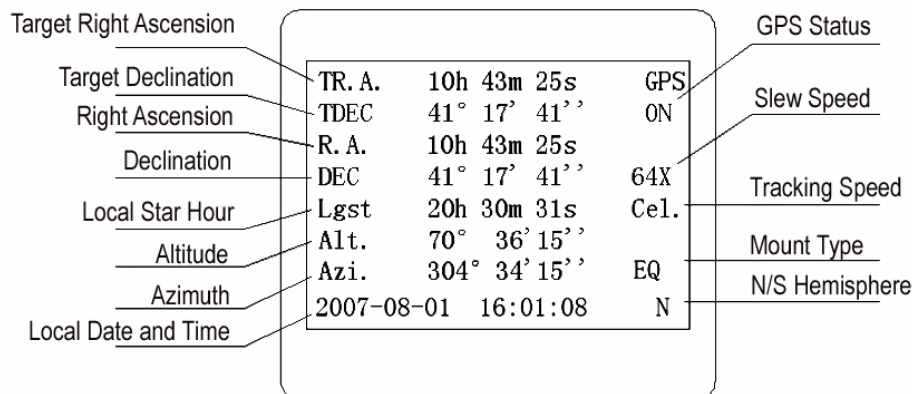

Figure 3. 8401 HC LCD Information Screen

3.2. The LCD Screen

The 8401 HC is designed to use for both iOptron's equatorial (EQ) mount, such as the SmartStar®-PR GOTO German Equatorial Mount and the GOTONOVA™ Equatorial Kit, and AltAzimuth (A/A) mount, which includes all SmartStar® GOTO mounts and telescopes. It consists of a large 8-line LCD screen, which displays all the information as shown in Figure 3. The user interface is simple and easy to learn.

- GPS status: When the power is turned on, it shows "GPS ON", which means a GPS receiver is connected. When the GPS receiver finds the satellite and receives GPS signal, it shows "GPS OK". The "GPS OK" may turn off after few minutes.
- Slew speed: It has 9 speeds: 1X, 2X, 8X, 16X, 64X, 128X, 256X(1°/sec), 512X(2°/sec), MAX(4°/sec).
- Tracking speed: It has 4 speeds: Cel (celestial), Sol (Solar), Lun (Lunar), Def (user defined)
- Mount Type: EQ is equatorial and A/A altazimuth.

3.3. Connection to a Computer

The GOTONOVA hand controller has a USB port which can be connected to a computer. This will allow Firmware Upgrading, Database Updating, or Planetarium application. A USB2COM driver is needed to simulate the USB port to a RS-232 serial port. (see Appendix D)

The CubePro™ can be controlled by a number of popular astronomy software programs. For astronomy software that does not have an embedded iOptron mount driver, an ASCOM driver and related platform are needed. Please refer to Appendix F for more information.

4. Getting Started

In order to experience the full GOTO capability of GOTONOVA technology, it is very important to set up the mount correctly before observation.

4.1. Level and Align the Mount

Each time the Mount is turned on, the default position is Parking Position, i.e., Alt. 90°0'0" and Azi. 180°0'0", which means the Mount is leveled, facing south and the telescope pointing up at the Zenith. The procedures are:

- Level the Mount. Adjust the leg length to make sure the bubble on the side of the mount is centered. Turn the Mount around to make sure it is always leveled. It is also recommended to use additional levels to assure very precise leveling. **Leveling is critical for a good GOTO and tracking accuracy.**

- Face the South. Align the Mount to south by turning the South mark facing south. An additional compass may be needed. There are two ways to do so.



One is loosen the AZI lock (7) a little and manually turn the Mount to face south. Then tighten the AZI lock again. The other is turn on the Mount. Turn the Mount facing south using hand control. Then turn off the power.

- Point to Zenith. Unlock the ALT Lock and turn the telescope to point up directed at the Zenith.

4.2. Setting Up the Mount

A CubePro is equipped with a GPS receiver, which will receive the local time, longitude and latitude information from a satellite after the link is established.



However, manual input is still needed for time zone and Daylight Saving setting.

A clear sky outside is needed for GPS to communicate well with the satellites.

4.2.1. Set Up Time Zone

Press MENU button, from the main menu, scroll down and select "Set up controller"

```
Select and slew
Sync. to target
Electronic focuser
Set up controller
Align
PEC option
Set up Tracking
User objects
```

Press ENTER. Scroll down and select "Set up site"

```
Set up Local Time
Set up site
Set N/S hemisphere
Set display contrast
Set Eyepiece light
Set Backlight
Set anti-backlash
Set Key Beep
```

Press ENTER. The longitude and latitude coordinates will be updated when the GPS picks up satellite signals. "W/E" means west/east hemisphere; "N/S" means north/south hemisphere; "d" means degree; "m" means minute; and "s" means second.

```
Set up site info:
Longitude:
    W071d27m47s
Latitude:
    N42d15m40s
300 Min. behind of UT
```

If for any reason your GPS can't pick up a signal you can manually enter the GPS coordinates. Press ◀ or ▶ key to move the cursor and using ▲ or ▼ key to toggle between "W" and "E", "N" and "S", using number key to change the numbers. It is always a good idea to do your home work to get the GPS coordinates before traveling to a new observation site.

The site coordinates information can be found from internet, such as GPSVisualizer (<http://www.gpsvisualizer.com/geocode>), by entering the city name or address. In case you only find the site information in decimal format you can convert them into d:m:s format by multiplying the decimal numbers by 60. For example, N47.53 can be

changed to N47°31'48": $47.53^\circ = 47^\circ + 0.53^\circ$, $0.53^\circ = 0.53 \times 60' = 31.8'$, $0.8' = 0.8 \times 60'' = 48''$. Therefore, $47.53^\circ = 47^\circ 31' 48''$ or 47d31m48s. Same as N47°31.8': $31.8' = 31' + 0.8'$, $0.8' = 0.8 \times 60'' = 48''$.

Press ◀ or ▶ key, move the cursor to the bottom of the screen to set the time zone information (add or subtract 60 minutes per time zone). Enter minutes “ahead of” or “behind” UT (universal time).

- New York City is 300 minutes “behind” UT
- Los Angeles is 480 minutes “behind” UT
- Rome is 60 minutes “ahead of” UT
- Beijing is 480 minutes “ahead of” UT
- Sydney is 600 minutes “ahead of” UT

All the time zones in North America are *behind* UT (universal time), as shown in the following table. So make sure it shows “behind” instead of “ahead of” UT.

Time Zone	Hours behind UT	Enter Minutes
Hawaii	-10	600
Alaska	-9	540
Pacific	-8	480
Mountain	-7	420
Central	-6	360
Eastern	-5	300

To adjust minutes, move the cursor to each digit and use the number keys to input number directly. To change the “behind” or “ahead” of UT, move the cursor to “ahead” and using ▲ or ▼ key to toggle between “behind” and “ahead”. When the number is correct, press ENTER and go back to the previous screen.

For other parts of the world, you can find out your “time zone” information from internet, such as

<http://www.timeanddate.com/worldclock/>.

DO NOT COUNT DAYLIGHT SAVING TIME.

4.2.2. Set Up Daylight Saving Time

Scroll up and select “Set up local Time”

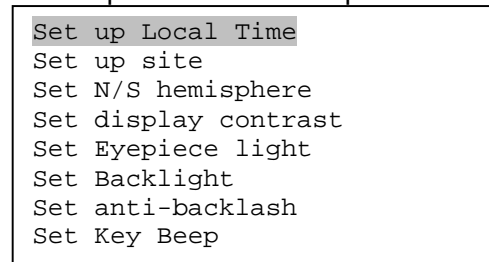

Press ENTER.

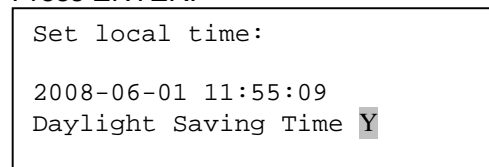

Use the ◀ or ▶ key to move the cursor to the bottom of the screen, use the ▲ or ▼ button to toggle between “Y” and “N”. Press ENTER to go back the previous screen. The local time also can be manually entered in case of GPS malfunction or testing the mount inside.

The time and site information will be stored inside HC memory chip. If you are not traveling to other observation site, they do not need to be changed.

4.2.3. Set Mount Type

The 8401 hand controller that comes with the CubePro can function in both EQ and AltAz. For the CubePro you will need to set the hand controller to function in AltAz. Scroll down and select “Set Mount Type”,

```

Set up site
Set N/S hemisphere
Set display contrast
Set Eyepiece light
Set Backlight
Set anti-backlash
Set Key Beep
Set Mount Type

```

Press Enter.

```

Equatorial Mount
Alt/Azi Mount

```

Select Alt/Azi mount and press ENTER to go back the previous screen.

4.2.4. Set Anti-backlash

For an Alt/Azi operation, both R.A. and DEC anti-backlash should be set to 0 step (factory default setting). Scroll down and select "Set anti-backlash"

```

Set up Local Time
Set up site
Set N/S hemisphere
Set display contrast
Set Eyepiece light
Set Backlight
Set anti-backlash
Set Key Beep

```

Press ENTER. A R.A. anti-backlash will display:

```

R.A. anti-backlash:
    0150      steps

One steps equal to
    1.5 arc second.

```

To adjust steps, move the cursor to each digit and use the number keys to input number directly. Press ENTER, a DEC anti-backlash will display:

```

DEC anti-backlash:
    0150      steps

```

```

One steps equal to
    1.5 arc second.

```

Move the cursor to each digit and use the number keys to set the anti-backlash to 0. Press ENTER to go back the previous screen.

Press BACK button to go back to main menu.

4.2.5. Go to the Moon

After performing these set-ups the mount is ready to GOTO and track objects. One of the most common objects is the Moon.

To slew to the Moon, press MENU button, select "Select and slew" by pressing the ENTER button. Select "Planets, Sun, Moon", and use the ▲ or ▼ buttons to select Moon. Press ENTER. The telescope will automatically slew to the Moon and lock on. It will automatically begin to track once it locks on. Use the arrow keys to center the Moon in your eyepiece if it is not centered. Or for better performance use Sync to Target (see instructions later).

4.2.6. Initial Star Alignment

A simple star alignment/synchronization can be performed to improve the GOTO and tracking accuracy. To do so, after slew the mount to an object, such as Moon, press MENU button, scroll down to "Sync. To Target", follow the on-screen instruction and press ENTER.

An alternate way is to perform an "Easy One Star Align". To do so, press MENU button, scroll down to "Align", select "Easy One Star Align" and press ENTER. The screen will list three bright objects for you to select from (ex. Moon, Jupiter, Venus).

Select an object using ▲ or ▼ key. Then press ENTER. Next use the arrow keys to slew to the object until it is centered in your eyepiece. Then press ENTER.

You may need using number keys to change the slewing speed to make the centering procedure easier.

4.3. Turn Off the Mount

When you are finished observing it is recommended to return the mount to Park Position. If the mount is not moved then no initial set up is needed when you turn on the mount next time. To park the telescope press the MENU button, scroll down to "Park Telescope" and press ENTER. Once the telescope returns to Park Position turn the power off.

5. Use the CubePro

5.1. Manual Operation of a Telescope

You may observe land and astronomical objects using GOTONOVA's arrow keys.

After the telescope was assembled (referring to Section 2. Telescope Assembly), flip the I/O switch on the telescope mount to turn on the mount. Use ►, ◀, ▼ or ▲ buttons to point the telescope to the desired object. You may need to use the number keys to change the slewing speed. Simply press a number while slewing to change the slew speed.

5.2. Slew to an Object

Press the MENU button. From the main menu select "Select and Slew." Select an object that you would like to observe and press the ENTER key.

The GOTONOVA™ 8401 hand controller has a database of about 130,000 objects. Use the ► or ◀ buttons to move the cursor and the ▼▲ buttons to change the

individual number. The check mark (√) indicates the object is above the horizon, and a cross mark (X) means it is below the horizon. In some catalogs those stars below the horizon will not display on the hand controller.

5.2.1. Planets, Sun, Moon

There are 10 objects in the Solar system catalog.

5.2.2. Deep sky objects

This menu includes objects outside our Solar system such as galaxies, star clusters, quasars, and nebulae.

- Named Deepsky Objects: consists of 60 deep sky objects with their common names. A list of named deep sky objects is attached in Appendix C.
- Messier Catalog: consists of all 110 objects.
- NGC IC Catalog: consists of 7840 objects in NGC catalog and 5386 objects in IC catalog. To select an object from NGC or IC catalog, move the cursor to NGC, using ▲ or ▼ button to toggle between NGC and IC. Then move the cursor to numerical position and use the number button to select the object.
- UGC Catalog: consists of 12939 objects.
- MCG Catalog: consists of 29004 objects. They are listed numerically from MCG+15 to MCG-05.
- Caldwell Catalog: consists of 109 objects.
- Abell Catalog: consists of 2712 objects.
- Herschel Catalog: consists of 400 objects.

5.2.3. Comets

This catalog contains up to 190 comets. This database is customer upgradeable.

5.2.4. Asteroids

This catalog contains up to 4096 asteroids. This database is customer upgradeable.

5.2.5. Stars

- **Named Stars:** consists of 191 stars with their common names. They are listed alphabetically. A list is attached in Appendix C.
- **Double Stars:** consists of 40 double stars. A list is attached in Appendix C.
- **GCVS Variable Stars:** consists of 38624 GCVS variable stars. They are listed numerically.
- **SAO Catalog:** consists of 26584 SAO catalog objects. They are listed numerically.

5.2.6. Constellations

This catalog consists of 88 modern constellations with their names. They are listed alphabetically. A list is attached in Appendix C.

5.2.7. User Objects

This catalog can consist up to 256 user predefined objects. These objects need to be entered before they can be selected for slewing.

5.2.8. Enter R.A. DEC

Here you can go to a target by entering its R.A. and DEC numbers.

5.3. Sync to Target

This operation will match the telescope's current coordinates to Target Right Ascension and Declination. After slew to an object, press MENU—then scroll to “Sync to Target” and press ENTER. Follow the screen to do the sync. Using this function will re-calibrate the computer to the

selected object. Multiple syncs can be performed if needed.

“Sync to Target” will only work after “Select and slew” is performed. Otherwise, the system may perform incorrectly. You can change the slewing speed to make the centering procedure easier. Simply press a number (1 through 9) to change the speed. The default slew speed is 64X.

“Sync to Target” does the same thing as one star alignment except that you choose the object to “sync” to. One star alignment chooses the star/object for you.

5.4. Electric Focuser

If you have an electric focuser in your system and it is supported by GOTONOVA, use this option to adjust the focuser. Use ◀▶ for coarse tuning and ▼▲ for fine tuning.

Refer to your Electric Focuser operation manual for detailed instruction.

5.5. Set Up Controller

5.5.1. Set Up Local Time

Refer to 4.2.2.

5.5.2. Set Up Site

Refer to 4.2.1.

5.5.3. Set N/S Hemisphere

Set north or south hemisphere.

5.5.4. Set Display Contrast

Use arrow keys to adjust LCD display contrast.

5.5.5. Set Eyepiece Light

If you have an illuminated-reticule eyepiece or illuminated polar scope, and it is supported by GOTO NOVA hand controller-- use this option to adjust the light intensity.

5.5.6. Set Backlight

Adjust LCD and keypad backlight.

5.5.7. Set Anti-backlash

Use Array Keys to move the cursor and Number Keys to change the number. 0 is suggested for Alt/Azi mount. For an EQ mount, the default setting is 150 for both DEC and R.A.

5.5.8. Set Key Beep

Turn the key beep on/off.

5.5.9. Set Mount Type

Although CubePro is an Alt/Azi mount the controller can be used for either Equatorial Mount or Alt/Azi Mount. This command changes between the two positions (EQ and AltAz).

5.5.10. Reset All

Reset all settings to factory default data.

5.5.11. Update Firmware

Firmware updating using iOptron Downloader through USB port on hand controller. (Refer to Appendix E.)

5.5.12. Set gear ratio

Reserved for future products.

5.5.13. Set Language

Select hand controller language.

5.6. Align

This function is used for aligning the telescope. In addition to "Easy One Star Align," the system also provides "One Star Align" and "Two Star Align" for Alt/Azi mount. "Three Star Align" is only supported by EQ mode.

5.6.1. One Star Align

From the main menu select "Align". Select "One Star Align". Use ▲ and ▼ buttons to select a star and press ENTER. A list of align planets or stars that are above the horizon is computed based on your local time and location. Use arrow buttons to move the telescope and center the star in your eyepiece. You can use the number buttons to change the slew speed.

Press ENTER when finished. If your setup is leveled well, one star alignment should be sufficient for good GOTO accuracy. To increase the accuracy you may choose to do two star alignment.

5.6.2. Two Star Align

Two star alignment will increase the GOTO accuracy of the mount. It is suggested to do two star alignment after one star alignment. Two star alignment requires a wider view of the sky, since the two align stars need to be far apart. Select "Two Star Align" in the Align menu. When you finish the first star, the system will prompt you to choose the second star. If the star you choose is too close to the first one, the system will let you choose another one. When you are aligned with the second star, two star alignment is finished. You can reject the suggested star if it is blocked by the tree or behind the house.

"Two Star Align" results will be overridden if "One Star Align" or "Sync. to Target" is performed after "Two Star Align."

5.6.3. Three-Star Align

It will increase the accuracy even higher and requires an even wider view of the sky. This basically asks you to choose a third star to align after two-star align. Three star alignment is not available for Alt/Azi mode.

5.6.4. Dis R.A axis error

This only works for EQ mode. This displays the celestial pole point error. Point error is zero when you power on the mount (unless you "Park Telescope" before powering off.

5.6.5. Test Anti-backlash

This command tests the backlashes in both R.A. and DEC. The saved numbers will show in "Set Anti-backlash" menu. However, if no high accuracy is needed or your equatorial mount is not a high accuracy unit (*i.e.* the worm gear has different clearance in different positions) you can omit this procedure.

This command only works for EQ mode.

5.6.6. Polaris Position

This shows Polaris position.

5.7. PEC Option

Periodic Error Correction (PEC) is not supported in Alt/Azi mode.

5.8. Set Up Tracking

A user can set up tracking in the main menu by selecting "Set up tracking". Then the user can select "Sidereal speed", "Solar speed", "Lunar speed", and "User defined speed". For "User defined speed" this can be adjusted from 91% to 109% of sidereal speed by pressing the ▲ or ▼ buttons.

5.9. User Objects

Besides various star lists available in the hand controller --you can add, edit or delete your own user-defined objects. All data you enter is supposedly J2000.0 epoch.

5.10. Auto Guide

This is an advanced function for autoguiding when a guiding scopes and a camera are equipped. The GOTONOVA supports autoguiding through ASCOM protocol, such as PHD Guiding or Guidedog, or an ST-4 guiding camera (an extra ST-4 to HBX adapter is needed). Please follow the guiding software for detailed instructions.

This function is not supported in Alt/Azi mode.

5.11. Park Scope

This procedure only needs to be done if you do not move your telescope mount after you power off the GOTONOVA. Celestial pole pointing error will be stored to flash memory and recalled when you power on again.

5.12. To Park Position

This moves your telescope to park position. When power is turned on--the mount assumes the physical position is the park position. This is its reference point for all other objects.

6. Maintenance and Servicing

6.1. Maintenance

The CubePro is designed to be maintenance free. Do not overload the mount. Do not drop the mount which will damage the mount or affect the GOTO tracking accuracy permanently. Use a wet cloth to clean the mount and hand controller. Do not use solvent.

If your mount is not to be used for an extended period, dismount the OTAs and counterweight. Remove the batteries from the battery holder if they were installed.

6.2. Troubleshooting

The following suggestions may be helpful for the operation of the CubePro. More information can be found in our online FAQ section (www.iOptron.com then click on "support").

1. Error Message "Warning! DEC. (or R.A.) driver motor over current. Please check balance."

1. Check if the mount or OTA is blocked by any obstructions.
2. Try to operate the mount without an OTA.
3. Check the power supply. This is a common reason for this message and **unexpected slew behavior or movement**. which include:
 - Batteries: Are the batteries fresh? How long have they been used? (frequent slewing and GOTO will deplete battery power very quickly)
 - AC or DC adapter: Check the plugs to the mount and to the power outlet.
 - Extension cord: Make sure the cord is in good condition. Power drop along the extension cord has been known to cause this error message.

Also check all the plugs and connections.

4. Check the hand controller cord. Unplug it and re-plug into the other HBX port.

5. Error Message "Warning! Can not communicate with DEC motor controller."

1. Check the hand controller cord. Unplug it and re-plug into another HBX port.
2. Check the power supply, which include:
 - Using the battery? Is the battery fresh? How long it has been used? (frequent slew and GOTO will deplete battery power very quickly)
 - Using AC or DC adapter? Check the plugs to the mount and to the power outlet.
 - Using extension cord? Make sure the cord is in good condition. Power drop along the extension cord was known to cause the problem. Also check all the plugs and connections.

3. The object is jumping up and down in the eyepiece or over-slewed, and other unexpected slew behavior or movement.

- (1) Use most updated firmware.
- (2) Set backlash to 0 in both DEC and RA.
- (3) Check the power supply, which include:
 - Using the battery? Is the battery fresh? How long it has been used? (frequent slew and GOTO will deplete battery power very quickly)
 - Using AC or DC adapter? Check the plugs to the mount and to the power outlet.
 - Using extension cord? Make sure the cord is in good condition. Power drop along the extension cord was known to cause the problem. Also check all the plugs and connections.
- (4) System balancing.

4. Star Alignment accuracy; GOTO accuracy

1. Leveling (very important).
2. Site information (minutes ahead or behind UT, DST).
3. System balancing.
4. Use most updated firmware.
5. Select right mount type (A/A).
6. Set backlash to 0 in both DEC and RA.
7. Check the power supply, which include:
 - Using the battery? Is the battery fresh? How long it has been used? (frequent slew and GOTO will deplete battery power very quickly)
 - Using AC or DC adapter? Check the plugs to the mount and to the power outlet.
 - Using extension cord? Make sure the cord is in good condition. Power drop along the extension cord was known to cause the problem. Also check all the plugs and connections.

6.3. iOptron Customer Service

If you have a question concerning your CubePro contact the iOptron Customer Service Department. Customer Service hours are 9:00 AM to 5:00 PM, Eastern Time, Monday through Friday. In the unlikely event that the CubePro requires factory servicing or repairs, write or call the iOptron Customer Service Department first to receive an RMA# before returning the telescope to the factory. Please provide details as to the nature of the problem as well as your name, address, and daytime telephone number. We have found that most problems can be resolved by telephone. So please call first to avoid returning the telescope for repair. Call toll free in the U.S. 1.866.399.4587 or 1.781.569.0200. It is also strongly suggested to send technical questions to support@ioptron.com .

Appendix A. Technical Specifications

Mount	AltAzimuth Mount
Body Materials	Die-cast Aluminum
Gear	Aluminum worm wheel/brass worm shaft
Bearing	4 steel ball bearings
Motor	Dual-Axis DC Servomotor, DC12V
Slew Speed	Dual-Axis, 9-Gear, Electronic (1×,2×,8×,16×,64×,128×,256×,512×,MAX)
GPS	32-channel GPS
GOTO System	GOTONOVA™ 120,000+ objects database
Tracking	Automatic
Payload	8 lbs
Counterweight	3.3 lbs (1.5kg)
Tripod	1" Stainless Steel
Battery	AA x 8 (Not Included)
Power Requirement	DC 12V±2V, >1.2A
Operating Temperature	0 ~ 40°C
USB Port	Yes
Firmware Upgrade	Yes
PC Computer Control	Yes
Weight with tripod	12 lbs

Appendix B. GOTONOVA™ 8401 HC MENU STRUCTURE

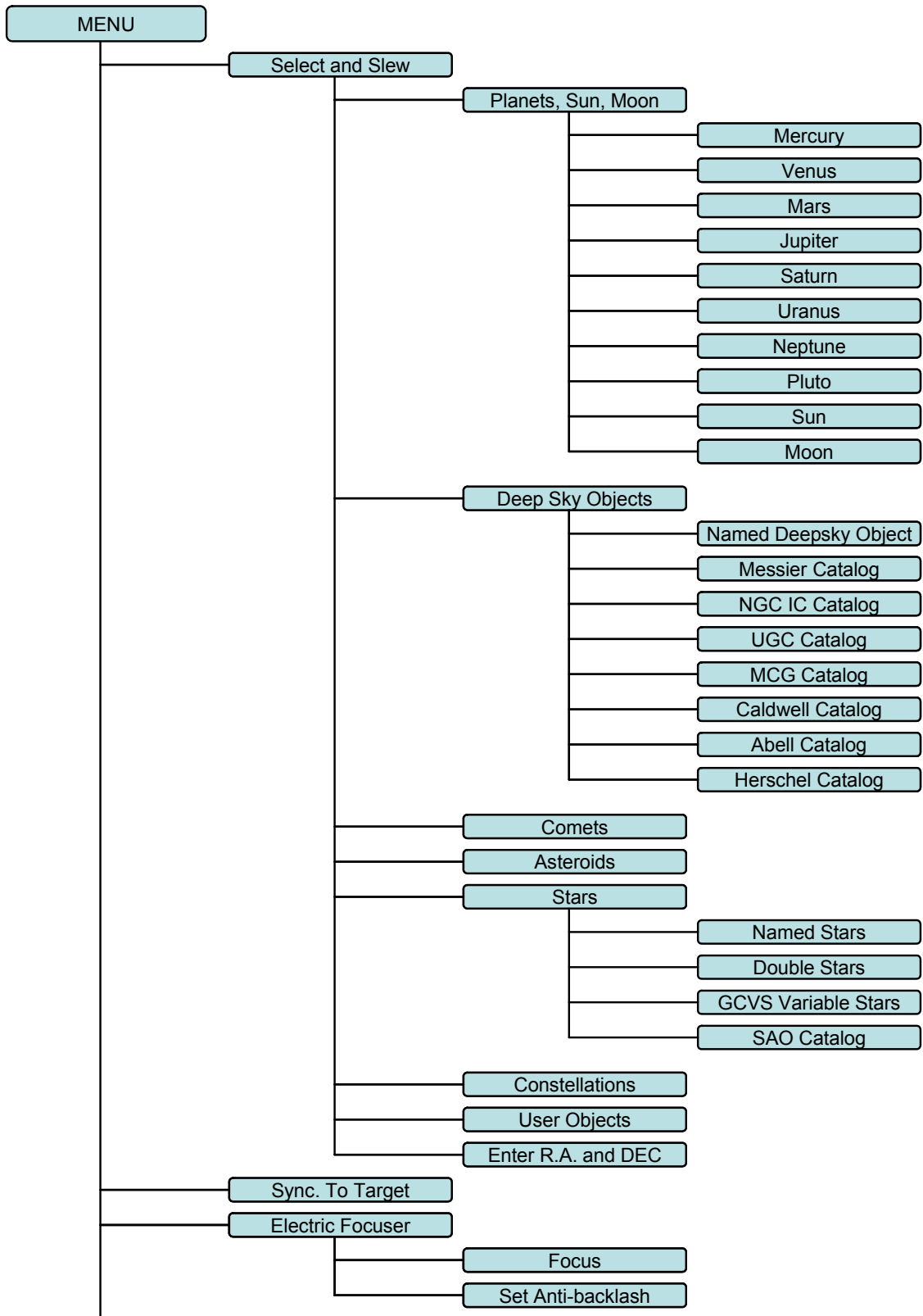

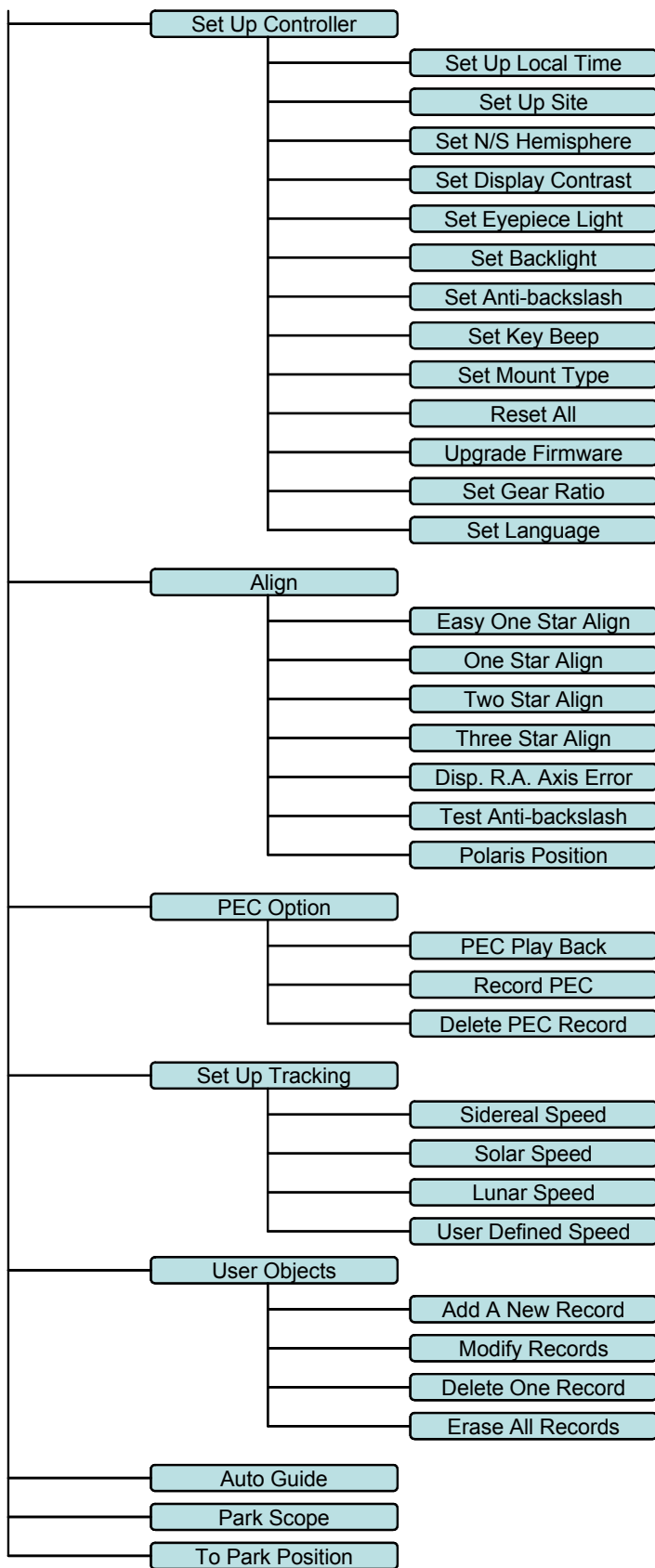

Appendix C. GOTONOVA™ Star List

GotoNova Deep Sky Object List

for 8401

ID No.	OBJECT	NGC #	Messier #	IC#	A(Abell)	U(UGC)
1	Andromeda Galaxy	224	31			
2	Barnards Galaxy	6822				
3	Beehive Cluster	2632	44			
4	Blackeye Galaxy	4926	64			
5	Blinking Planetary Nebula	6826				
6	Blue Flash Nebula	6905				
7	Blue Planetary	3918				
8	Blue Snowball Nebula	7662				
9	Box Nebula	6309				
10	Bubble Nebula	7635				
11	Bipolar Nebula	6302				
12	Butterfly Cluster	6405	6			
13	California Nebula	1499				
14	Cat's Eye Nebula	6543				
15	Cocoon Nebula			5146		
16	Cone Nebula	2264				
17	Cork Nebula	650-51	76			
18	Crab Nebula	1952	1			
19	Crescent Nebula	6888				
20	Draco Dwarf					10822
21	Duck Nebula	2359				
22	Dumbbell Nebula	6853	27			
23	Eagle Nebula		16			
24	Eight-Burst Nebula	3132				
25	Eskimo Nebula	2392				
26	Flaming Star Nebula			405		
27	Ghost of Jupiter	3242				
28	Great Cluster	6205	13			
29	Helix Nebula	7293				
30	Hercules Galaxy Cluster				2151	
31	Hind's Variable Nebula	1555				
32	Hubble's Variable Nebula	2261				
33	Integral Sign Galaxy					3697
34	Jewel Box Cluster	4755				

35	Keyhole Nebula	3372				
36	Lagoon Nebula	6523	8			
37	Little Gem	6445				
38	Little Gem Nebula	6818				
39	Little Ghost Nebula	6369				
40	North American Nebula	7000				
41	Omega Nebula	6618	17			
42	Orion Nebula	1976	42			
43	Owl Nebula	3587	97			
44	Pelican Nebula			5070		
45	Phantom Streak Nebula	6741				
46	Pinwheel Galaxy	598	33			
47	Pleiades		45			
48	Ring Nebula	6720	57			
49	Ring Tail Galaxy	4038				
50	Rosette Nebula	2237				
51	Saturn Nebula	7009				
52	Sextans B Dwarf					5373
53	Small Magellanic Cloud	292				
54	Sombrero Galaxy	4594	104			
55	Spindle Galaxy	3115				
56	Tank Track Nebula	2024				
57	Trifid Nebula	6514	20			
58	Ursa Minor Dwarf					9749
59	Whirlpool Galaxy	5194	51			
60	Wild Duck Cluster	6705	11			

Modern Constellations

No.	Constellation	Abbreviation
1	Andromeda	And
2	Antlia	Ant
3	Apus	Aps
4	Aquarius	Aqr
5	Aquila	Aql
6	Ara	Ara
7	Aries	Ari
8	Auriga	Aur
9	Boötes	Boo
10	Caelum	Cae
11	Camelopardalis	Cam
12	Cancer	Cnc
13	Canes Venatici	CVn
14	Canis Major	CMA
15	Canis Minor	CMi
16	Capricornus	Cap
17	Carina	Car
18	Cassiopeia	Cas
19	Centaurus	Cen
20	Cepheus	Cep
21	Cetus	Cet
22	Chamaeleon	Cha
23	Circinus	Cir
24	Columba	Col
25	Coma Berenices	Com
26	Corona Australis	CrA
27	Corona Borealis	CrB
28	Corvus	Crv
29	Crater	Crt
30	Crux	Cru
31	Cygnus	Cyg
32	Delphinus	Del
33	Dorado	Dor
34	Draco	Dra
35	Equuleus	Equ
36	Eridanus	Eri
37	Fornax	For
38	Gemini	Gem
39	Grus	Gru
40	Hercules	Her
41	Horologium	Hor
42	Hydra	Hya
43	Hydrus	Hyi
44	Indus	Ind

No.	Constellation	Abbreviation
45	Lacerta	Lac
46	Leo	Leo
47	Leo Minor	LMi
48	Lepus	Lep
49	Libra	Lib
50	Lupus	Lup
51	Lynx	Lyn
52	Lyra	Lyr
53	Mensa	Men
54	Microscopium	Mic
55	Monoceros	Mon
56	Musca	Mus
57	Norma	Nor
58	Octans	Oct
59	Ophiuchus	Oph
60	Orion	Ori
61	Pavo	Pav
62	Pegasus	Peg
63	Perseus	Per
64	Phoenix	Phe
65	Pictor	Pic
66	Pisces	Psc
67	Piscis Austrinus	PsA
68	Puppis	Pup
69	Pyxis	Pyx
70	Reticulum	Ret
71	Sagitta	Sge
72	Sagittarius	Sgr
73	Scorpius	Sco
74	Sculptor	Scl
75	Scutum	Sct
76	Serpens	Ser
77	Sextans	Sex
78	Taurus	Tau
79	Telescopium	Tel
80	Triangulum	Tri
81	Triangulum Australe	TrA
82	Tucana	Tuc
83	Ursa Major	UMa
84	Ursa Minor	UMi
85	Vela	Vel
86	Virgo	Vir
87	Volans	Vol
88	Vulpecula	Vul

GOTONOVA Named Star List

for 8401

001 Acamar	049 Ascella	097 Kaus Australis	145 Rassalas
002 Achernar	050 Asellus Australis	098 Kaus Borealis	146 Rasagethi
003 Acrux	051 Asellus Borealis	099 Kaus Media	147 Rasalhague
004 Acubens	052 Aspidiske	100 Keid	148 Rastaba
005 Adhafera	053 Atik	101 Kitalpha	149 Regulus
006 Adhara	054 Atlas	102 Kochab	150 Rigel
007 Al Na'ir	055 Atria	103 Kornephoros	151 Rigel Kentaurus
008 Albali	056 Avoir	104 Kurhah	152 Ruchbah
009 Alberio	057 Azha	105 Lesath	153 Rukbat
010 Alchibar	058 Baten Kaitos	106 Maia	154 Sabik
011 Alcor	059 Beid	107 Marfik	155 Sadachbia
012 Alcyone	060 Bellatrix	108 Markab	156 Sadalbari
013 Aldebaran	061 Betelgeuse	109 Matar	157 Sadalmelik
014 Alderamin	062 Biham	110 Mebsuta	158 Sadalsuud
015 Alfirk	063 Canopus	111 Megrez	159 Sadr
016 Algedi	064 Capella	112 Meissa	160 Saiph
017 Algenib	065 Caph	113 Mekbuda	161 Scheat
018 Algiebra	066 Castor	114 Menkalinan	162 Schedar
019 Algol	067 Celabrai	115 Menkar	163 Seginus
020 Algorab	068 Celaeno	116 Menkent	164 Shaula
021 Alhena	069 Chara	117 Menkib	165 Sheiak
022 Alioth	070 Chertan	118 Merak	166 Sheratan
023 Alkaid	071 Cor Caroli	119 Merope	167 Sirius
024 Alkalurops	072 Cursa	120 Mesartim	168 Skat
025 Alkes	073 Dabih	121 Miaplacidus	169 Spica
026 Almach	074 Deneb	122 Mintaka	170 Sterope
027 Alnasl	075 Deneb Algedi	123 Mira	171 Sulafat
028 Alnilam	076 Deneb Kaitos	124 Mirach	172 Syrma
029 Alnitak	077 Denebola	125 Mirfak	173 Talitha
030 Alphard	078 Dubhe	126 Mirzam	174 Tania Australis
031 Alphecca	079 Edasich	127 Mizar	175 Tania Borealis
032 Alpheratz	080 Electra	128 Muphrid	176 Tarazed
033 Alrakis	081 Elnath	129 Muscida	177 Taygeta
034 Alrescha	082 Eltanin	130 Nashira	178 Thuban
035 Alshain	083 Enif	131 Nekkar	179 Unukalhai
036 Altair	084 Errai	132 Nihal	180 Vega
037 Altais	085 Fomalhaut	133 Nunki	181 Vindemiatrix
038 Alterf	086 Furud	134 Nusakan	182 Wasat
039 Aludra	087 Gacrux	135 Peacock	183 Wazn
040 Alula Australis	088 Gausar	136 Phact	184 Yed Posterior
041 Alula Borealis	089 Gienah	137 Phecda	185 Yed Prior
042 Alya	090 Gomeisa	138 Pherkad	186 Zaniah
043 Ancha	091 Graffias	139 Pleione	187 Zaurak
044 Ankaa	092 Groombridge 1830	140 Polaris	188 Zavijava
045 Antares	093 Grumium	141 Pollux	189 Zosma
046 Arcturus	094 Hamal	142 Porrima	190 Zubenelgenubi
047 Arkab	095 Homan	143 Procyon	191 Zubeneshamali
048 Arneb	096 Izar	144 Propus	

GOTONOVA Double Star List

for 8401

No.	Object	Const	SAO	Name
1	Eta	Cas	21732	Achird
2	Alpha	Psc	110291	Alrisha
3	Theta	Per	38288	
4	Alpha	For	168373	Fornacis
5	Alpha	Aur	40186	Capella
6	Sigma	Ori	132406	
7	Mu	Ori	113389	
8	Alpha	CMa	151881	Sirius
9	Delta	Gem	79294	Wasat
10	Alpha	Gem	60198	Castor
11	Alpha	CMi	115756	
12	Epsilon	Hya	117112	
13	HR 3579		42642	
14	Kapa	UMa	42661	
15	Psi	Vel	221234	
16	Gamma	Leo	81298	Algieba
17	HR 4167		222199	
18	Mu	Vel	222321	
19	Alpha	UMa	15384	Dubhe
20	Zeta	UMa	28737	Mizar
21	Iota	Leo	99587	
22	Gamma	Cen	223603	
23	Gamma	Vir	138917	Porrima
24	Beta	Mus	252019	
25	HR 5089		204545	
26	Alpha	Cen	252838	
27	Zeta	Boo	101145	
28	Gamma	Lup	225938	
29	Gamma	CrA	83958	
30	Xi	Sco	159665	
31	Alpha	Sco	184415	Antares
32	Lambda	Oph	121658	Marfic
33	Zeta	Her	65485	
34	Eta	Oph	160332	Sabik
35	70	Oph	123107	
36	Zeta	Sgr	187600	Ascella
37	Delta	Cyg	48796	
38	Beta	Del	106316	Rotanev
39	Tau	Cyg	71121	
40	Epsilon	Lyr	67310	double double

Appendix D. Set Up USB-PC Connection

1. Download USB2COM driver (cp2102.zip file for 8401) from iOptron Website
2. Install cp2101(usb2com) driver

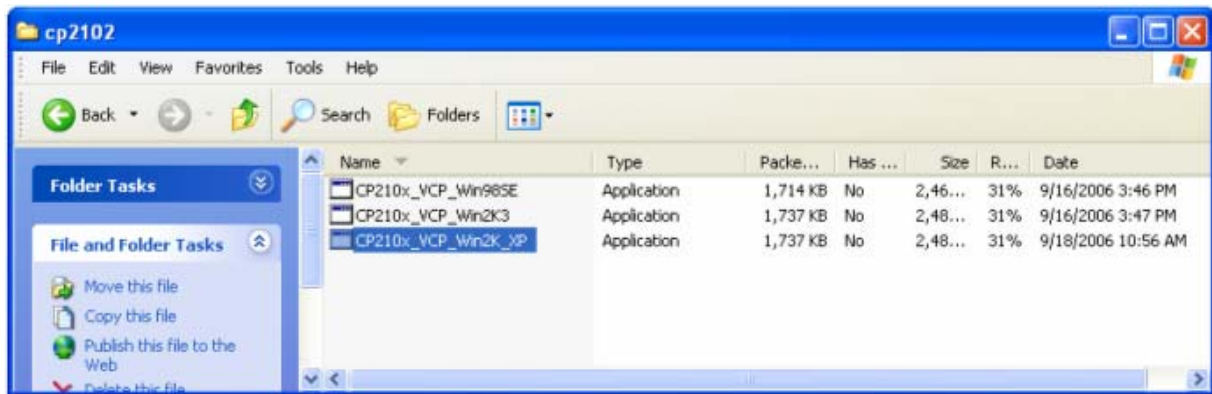

Choose the appropriate driver for your OS. In this case is a Windows XP operation system. Double click on it, and you will see:

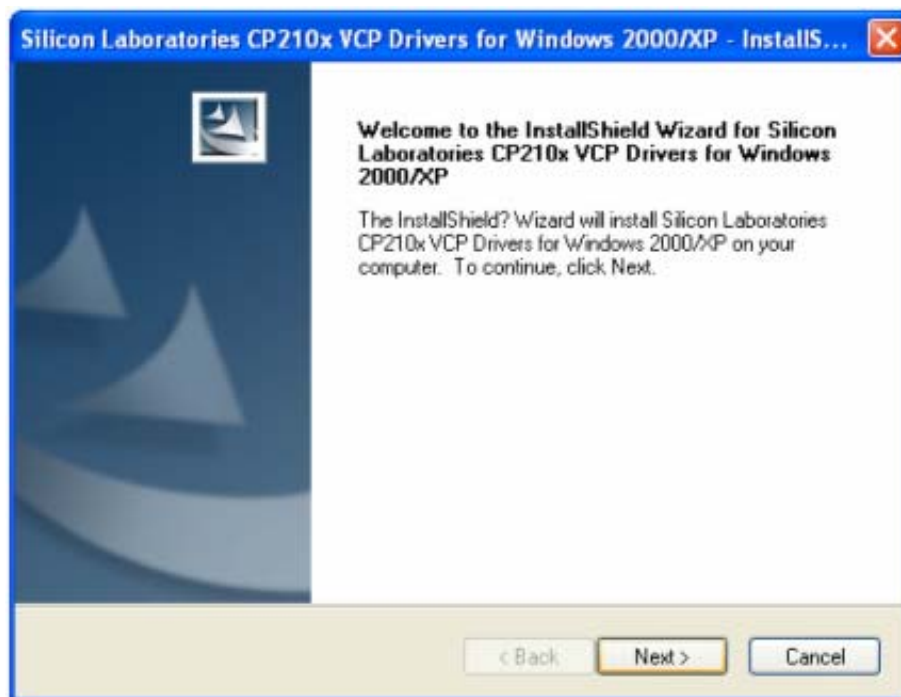

Click "Next".

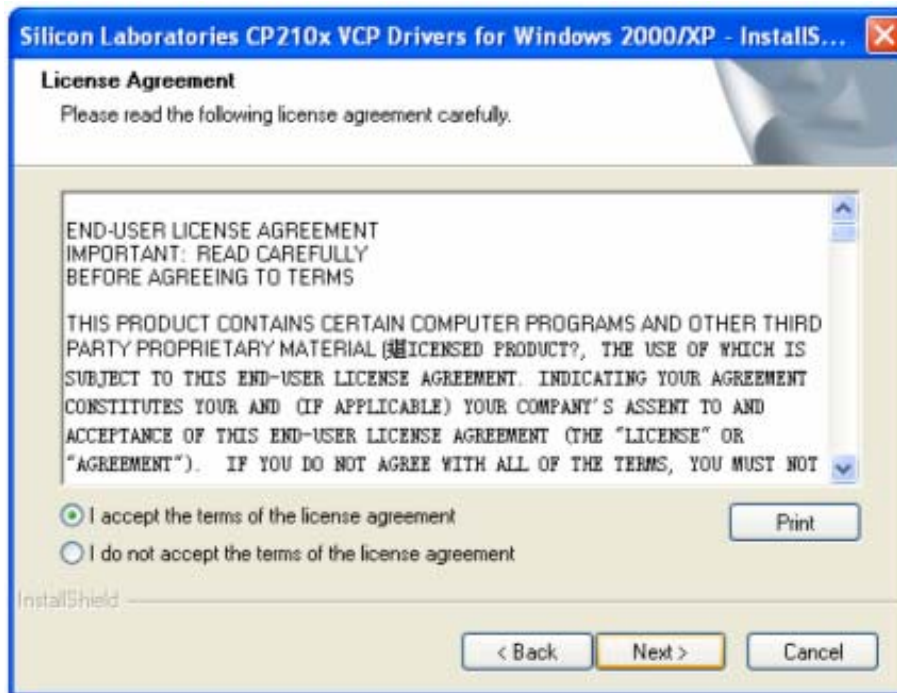

Select "I accept the terms of license agreement", and click "Next"

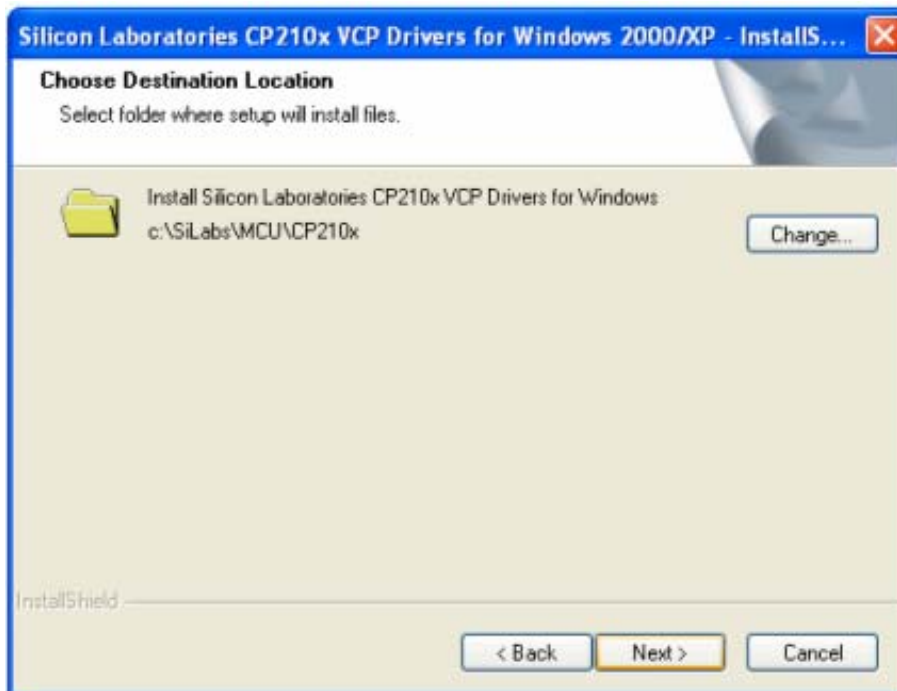

Using the default installation path, c:\SiLabs\MCU\CP210x, or specify your own path by click "Change". Click "Next". Then click "Install".

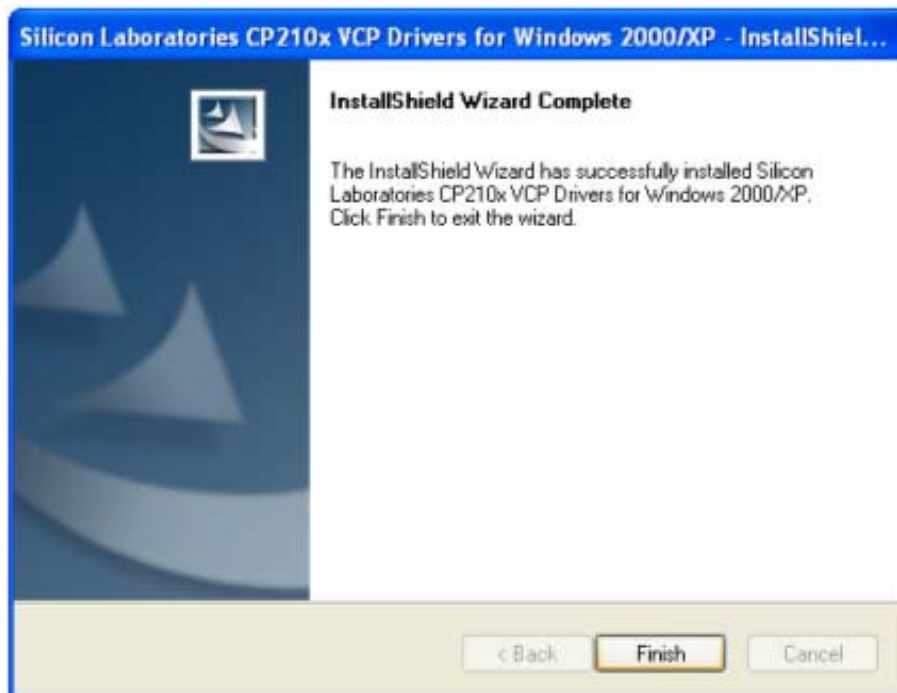

When finished installation, click "Finish"

3. Plug the USB cable to the USB port on your PC, plug the other end of the USB cable to hand controller. Turn on the power on the mount.

4. Install the Hardware

The computer will find a new hardware and show the following screen



Select "No, not this time" and click "Next".



Select “Install from a list or specific location” and click “Next”.

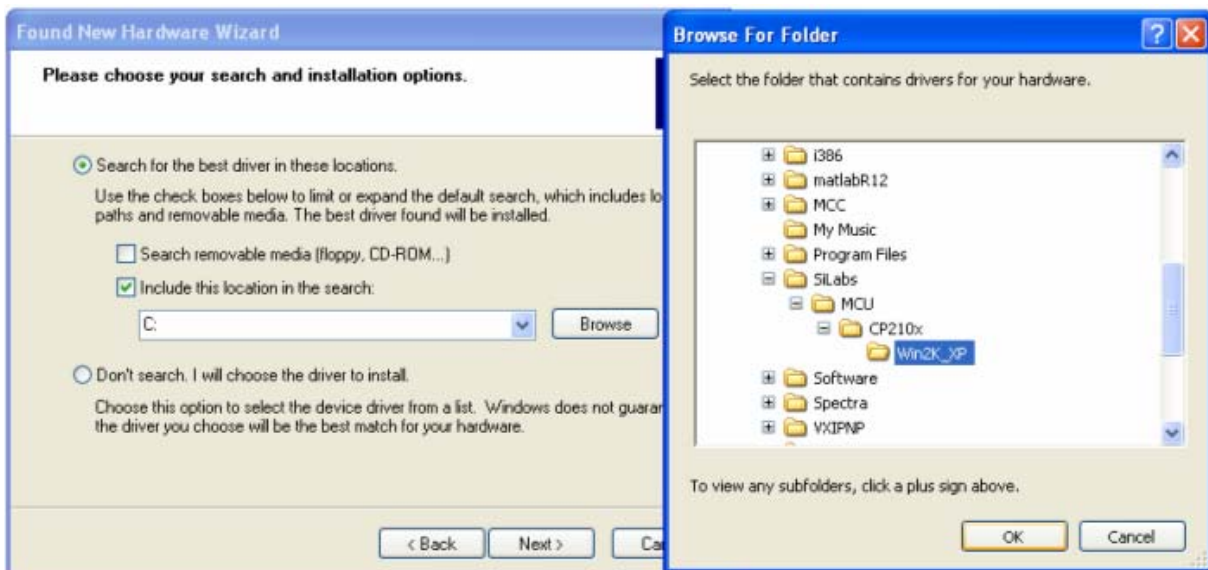

Select “Search for the best driver in these locations,” and check “Include this location in the search.”

Click on “Browse” and select the cp210x driver from directory c:\SiLabs\MCU\CP210x\Win2K_XP, click OK.

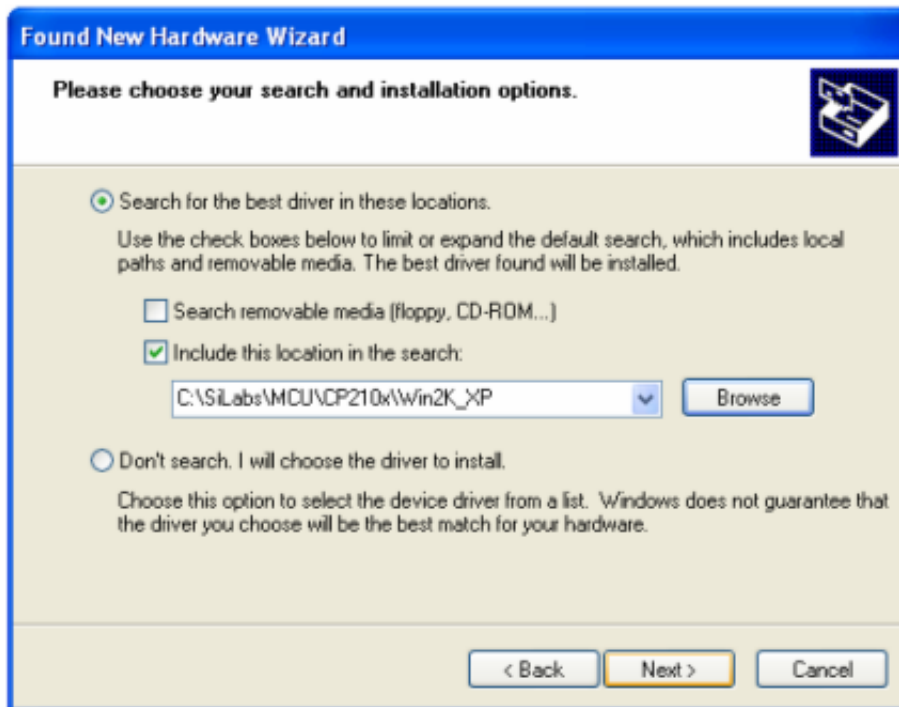

Click “Next”. The computer will start to install the driver for the USB2COM. When the installation is done, click “Finish”.



If the computer shows “find a new hardware” screen again, just repeat the steps in this section again.

Now your computer should be ready for Firmware Upgrading, computer communication with the mount via ASCOM platform and planetarium software applications. However, you need to find the assigned COM port number for the USB connection. To do so, right-click "My Computer", and click "Properties"



Click "Hardware", click "Device Manager"

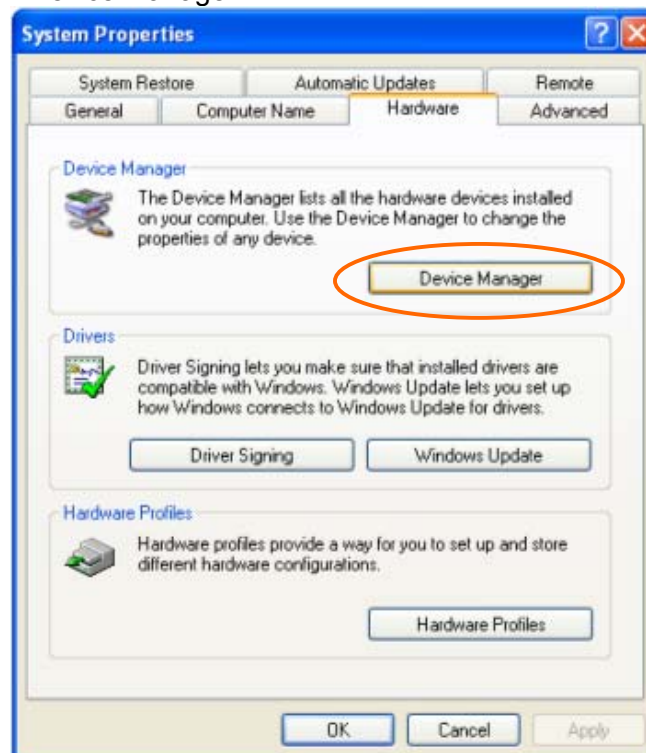

Double click on “Ports(COM & LPT)”, find out the COM number and write it down (in the following figure, it is COM4)

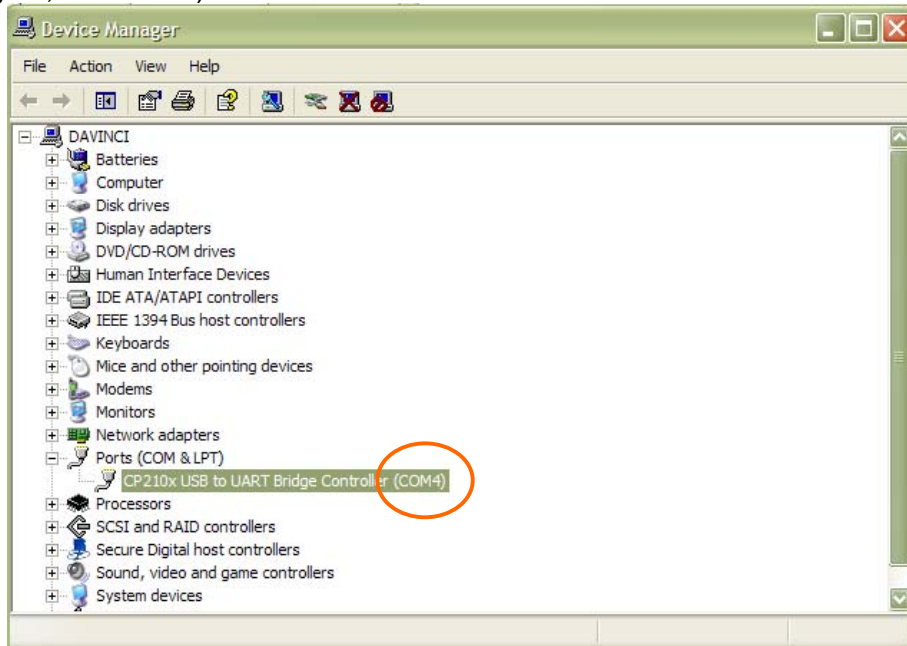

Appendix E. Firmware Upgrade

1. Download and install Firmware Downloader from iOptron Website
2. Double click and open “iOptron Downloader”

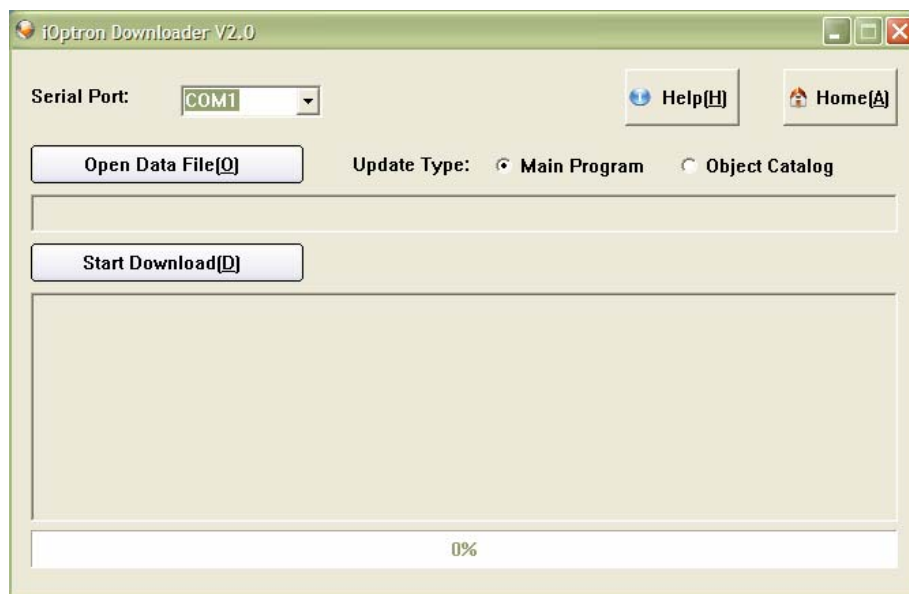

On the interface, select appropriate port using pull-down menu (in this case, COM4):

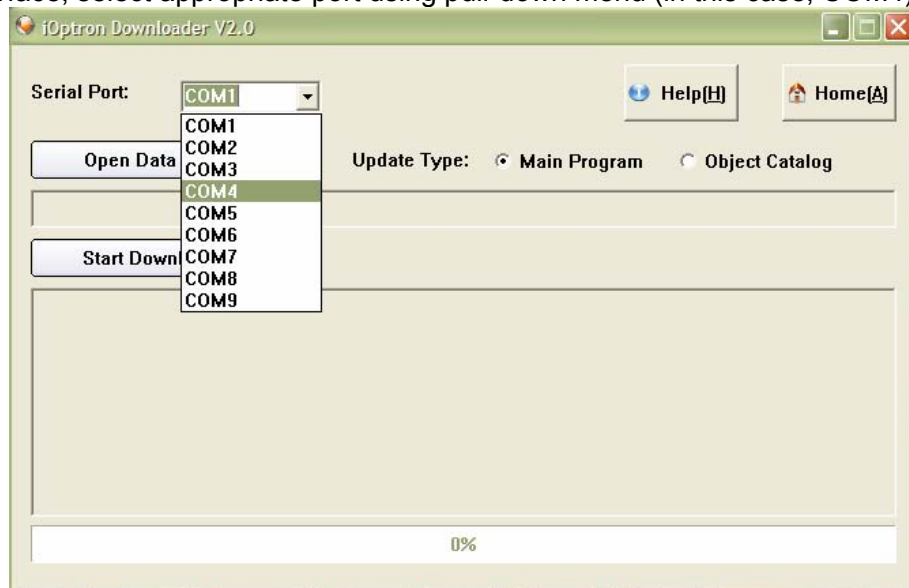

Click “Open Data File”, and select appropriate “.bin” file that matches your hand controller.

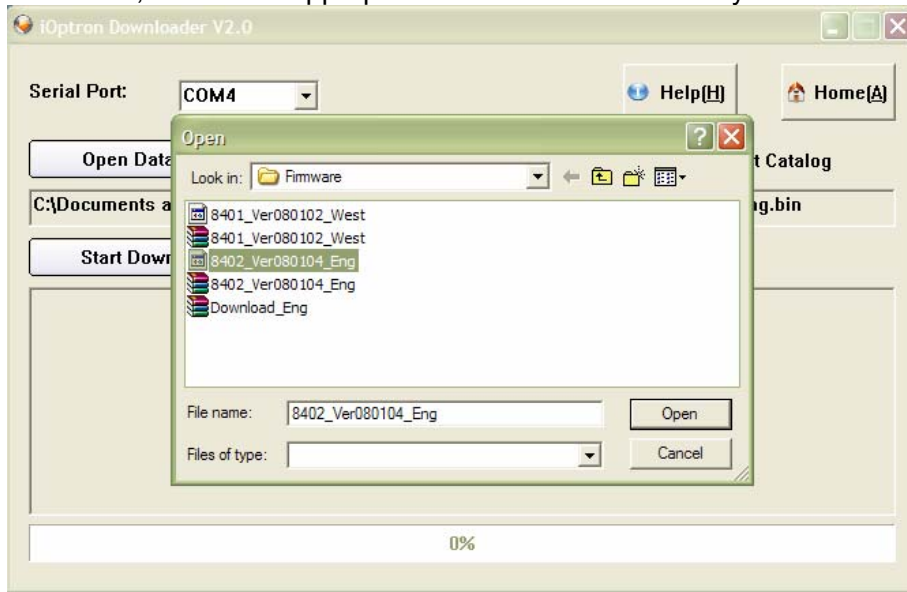

and click “Open”. Select “Main Program” in Update Type.

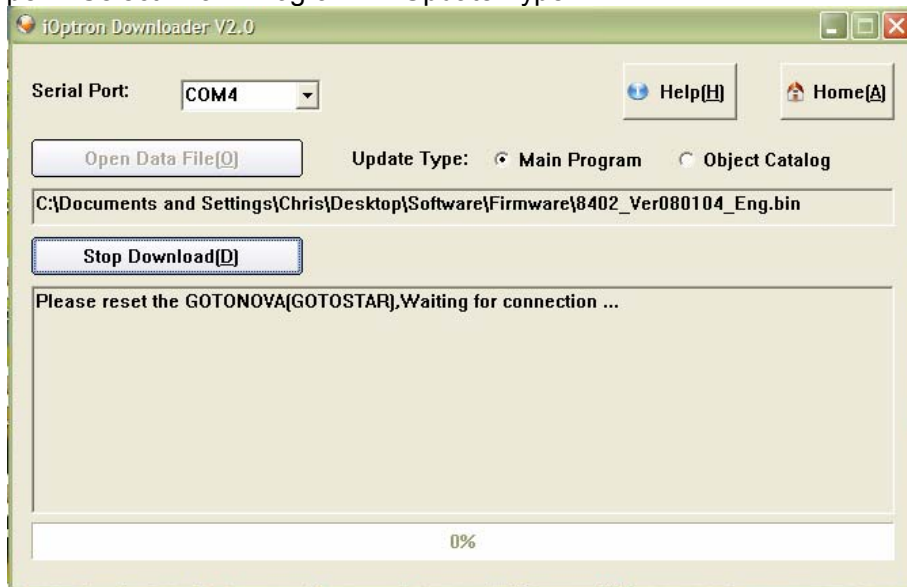

Click “Start Download”

It shows “Please reset GOTONOVA[GOTOSTAR], waiting for connection...”

On the hand controller, press “MENU”, and using ▼▲ scroll to select “Set up controller”, press “ENTER”, then select “Upgrade firmware”, press “ENTER” and the upgrade starts.

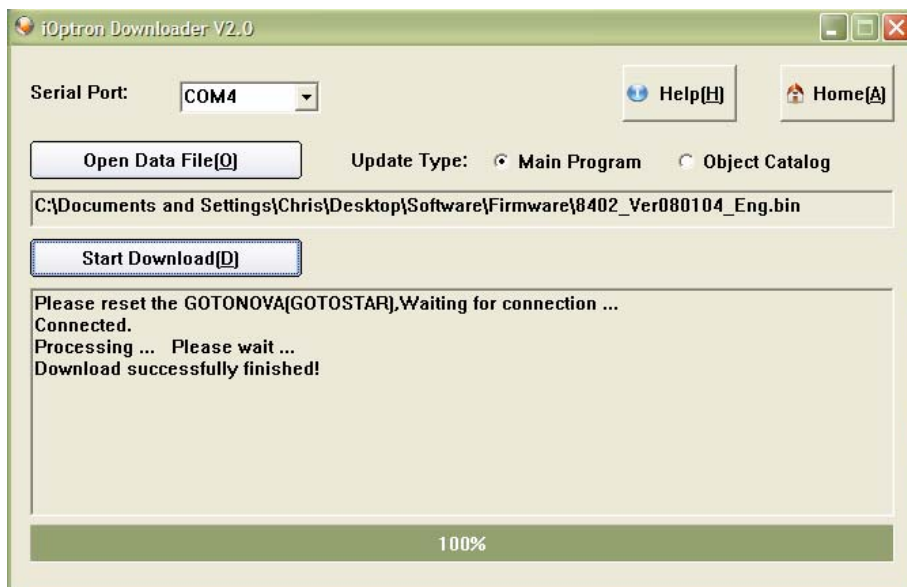
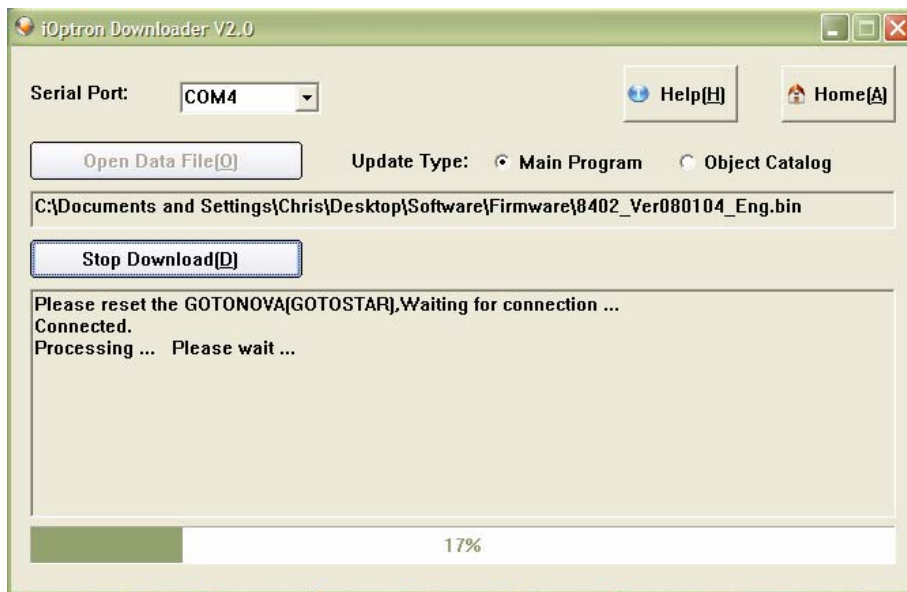

Now the upgrade is finished.

Typical Errors:

1. Invalid Port Number: in Device Manager, make sure you have the correct COM port number for CP210x.
2. Wrong ".bin" file: make sure you have the correct ".bin" file for firmware upgrade.
3. Wrong downloader, you should use iOptron Downloader instead of the Flash Downloader.
4. Use cp210x driver provided by iOptron. The newest version from SiLab may not work properly for iOptron's hand controller.

Appendix F. Use a PC to Control an iOptron Mount

In general you need the followings to use a PC to control the mount,

1. Download USB2COM driver (cp2102, zip file for 8401 and 8402A)
http://www.ioptron.com/manuals/USB_2COM_Driver.zip;
2. Install USB2COM and establish the connection between the mount and the PC (see instruction);
3. ASCOM platform (download from <http://ascom-standards.org/>);
4. iOptron ASCOM drive (download it from iOptron website
<http://www.ioptron.com/Files/File/iOptronAscomSetupV1.02.rar>); and
5. Planetarium software.

Some company integrated iOptron's products into their planetarium software, such as Voyage and The Sky X Pro. Therefore, an ASCOM plug-in will not be needed. Most planetarium software can be used to control iOptron's product via ASCOM.

Some other ASCOM drivers, such as LX200 Generic ASCOM driver and AstroPhysics GTO driver, are also compatible to SmartStar[®] mount.

Appendix G. RS-232 Command Set

Abbreviations used:

DD or DDD degrees or day of the month depending on the context
HH hours
MM minutes or month depending on the context
MM.M minutes and tenths of minutes
s + or – sign, assumed to be + if omitted
SS seconds
SS.S seconds and tenths of seconds
YY last two digits of the year

General Telescope Information:

Command: :SG sHH#

Response: "1"

Set the offset from Greenwich mean time. The offset can be entered in signed format (-12 to +12) hours.

Command: :Sg sDDD*MM:SS#

Response: "1"

Set the current longitude. The east is positive while the west is negative.

Command: :St sDD*MM:SS

Response: "1"

Set the current latitude.

Command: :SL HH:MM:SS#

Response: "1"

Set the current local time.

Command: :SC MM/DD/YY#

Response: 32 spaces followed by "#", followed by 32 spaces, followed by "#"

Set the current date.

Command: :GG#

Response:

East Longitude E HH:00#

West Longitude W HH:00#

Get the offset from Greenwich mean time.

Command: :Gg#

Response: sDDD*MM:SS#

Get the current longitude.

Command: :Gt#

Response: sDD*MM:SS#

Get the current latitude.

Command: :GL#

Response: HH:MM:SS.S#

Get the current local time in 24 hour format. Overflows from 23:59:59 to 00:00:00.

Command: :GS#

Response: HH:MM:SS.S#

Get the current local sidereal time in 24 hr. format.

Command: :GR#

Response: HH:MM:SS.S#

Get the current Right Ascension of mount.

Command: :GD#

Response: sDD*MM:SS#

Get the current Declination.

Command: :GA#

Response: sDD*MM:SS#

Get the current Altitude.

Command: :GZ#

Response: sDD*MM:SS#

Get the current Azimuth.

Command: :GC#

Response: MM:DD:YY#

Get the current calendar day.

Telescope Motion

Command: :MS#

Response: "0" if command accepted,

"1Object is below horizon #" the desired object is below 0 degrees altitude. (8 trailing spaces before "#", 32 total characters plus "#")

Target command: Slew to the most recently defined RA and DEC coordinates in RA-DEC mode,

Command: :Mn# :Ms# :Me# :Mw#

Response: (none)

Command motion in the direction specified (n=north, s=south, e=east, w=west) at the currently selected guide or centering rate. Motion will continue until a quit command is issued.

Command: :Qn# :Qs# :Qe# :Qw#

Response: (none)

Stop motion in the specified axis. Note that :Qn# is identical to :Qs#, and :Qe# is identical to :Qw#. Motion is terminated only if it was not started by a slew (:MS#) command.

Command: :Q#

Response: (none)

Motion in both axes is stopped, regardless of how the motion was invoked.

Command: :RG#

Response: (none)

Selects guide. If tracking is stopped, turns tracking on.

Command: :RC#

Response: (none)

This command sets to quit guide mode.

Command: :RCn#

Response: (none)

:RC0 # Set moving speed by N-S-E-W Keys to 16x

:RC1 # Set moving speed by N-S-E-W Keys to 64x

:RC2 # Set moving speed by N-S-E-W Keys to 256x

:RC3 # Set moving speed by N-S-E-W Keys to 512x

Command: :pS#

Response: "East#" or "West#"

This command returns the side of the pier on which the telescope is currently positioned.

Position

Command: :CM#

Response: "Coordinates matched. #"

(there are 5 spaces between "Coordinates" and "matched", and 8 trailing spaces before the "#", the total response length is 32 character plus the "#").

Calibrate mount. Current Right Ascension and Declination become the commanded Right Ascension and Declination. This command does the same thing as synchronize to target. This command should be used after a ":MS#" command has been finished. This means a GOTO must be done first.

Command: :CMR#

Response: "Coordinates matched. #"

(there are 5 spaces between "Coordinates" and "matched", and 8 trailing spaces before the "#", the total response length is 32 character plus the "#").

Calibrate mount. Current Right Ascension and Declination become the commanded Right Ascension and Declination. This command synchronizes HC coordinate to commanded coordinate. No GOTO needs to be done first.

Command: :Sr HH:MM:SS.S#

Response: "1"

Define the commanded Right Ascension, RA.

Command: :Sd sDD*MM:SS#

Response: "1"

Define the commanded Declination.

Miscellaneous

Command: :F+# :F-# :FF# :FS# :FQ#

Response: (none)

Advances (F+) or retracts (F-) focus adjust motor on the eyepiece. F+ or F- commands commence adjustment and :FQ# stops it. If :FS# has been issued previously, then the focus adjustment will be slow. If the :FF# command has been issued, then the adjustment will be fast. If neither FF nor FS is specified, the power up default of FS is assumed.

Command: :F1# :F2# :F3# :F4#

Response: (none)

Set the focus speed to 1,2,3,4, from slow to fast.

Command: :V#

Response: (current servo controller software RS232 command language version number)

This command returns the current servo controller software RS232 command language version.

Command: :Vs#

Response: (current servo controller software information)

This command returns the current servo controller software information.

Command: :STR0#,:STR1#,:STR2#

Response: '1'

This command sets the track rate.

0 - sidereal

1- solar

2- lunar

Command: :GTR#

Response: '0','1','2'

This command gets the current tracking rate.

0 - sidereal

1 – solar

2 - lunar

Command: :SGS0#,:SGS1#,:SGS2#,:SGS3#,

Response: (none)

This command sets the guide rate.

- 0 – 1.0X of sidereal
- 1 – 0.8X of sidereal
- 2 – 0.6X of sidereal
- 3 – 0.4X of sidereal

Command: :GGS#

Response: '0','1','2','3'

This command gets the current guide rate.

- 0 – 1.0X of sidereal
- 1 – 0.8X of sidereal
- 2 – 0.6X of sidereal
- 3 – 0.4X of sidereal

Command: :SE?#

Response: '0','1',

This command gets the slewing status.

- '1' in slewing
- '0' not in slewing

Command: :GAM#

Response: '0','1', '2'

This command gets the current mount type.

- 0 – Altitude/Azimuth type
- 1 – fork mount
- 2 – Germany equator mount

Command: :PK#"

Response: '1'

This command parks the telescope .

Command: : STPKP0#, :STPKP1#, :STPKP2#, :STPKP3#, :STPKP4#,

Response: '1'

These command sets the mount park position.

- 0 – original to north pole
- 1 - Left and vertical
- 2 - Left and horizon
- 3 - Right and vertical
- 4 - Right and horizon